



KT-LED112P-V-8xx-X

2-PIN LED LAMP

DESCRIPTION

11W 2-Pin LED Lamp | 2700K, 3000K, 4000K | ≥ 83 CRI | Magnetic Ballast and Line Voltage Compatible



LAMP TYPE: Compact
BULB TYPE: 2-Pin LED
BASE TYPE: G24d
WATTAGE: 11W
COLOR TEMPERATURE: 2700K, 3000K, 3500K, 4000K, 5000K
COLOR RENDERING INDEX (CRI): ≥ 83
WARRANTY: 5 Years



PRODUCT FEATURES

- Plug & Play Application: Replaces 18W/26W G24d CFL Lamps
- Bypass Ballast Application: Replaces 26W/32W/42W G24d & G24q CFL Lamps
- 50,000+ Hour Lifetime
- Approximately 50% More Energy Efficient than Traditional CFL Lamps
- Environmentally Friendly: No Mercury Used
- Instant Startup
- Frosted Lens Eliminates Pixelation
- UL Listed & UL Classified
- Operating Temperature: -20°C/-4°F to 45°C/113°F
- Up to 5x Longer Life than Traditional CFL Lamps

OPERATING SPECIFICATIONS

PLUG & PLAY ELECTRICAL CHARACTERISTICS

Input Voltage	Lamp Wattage	Power Factor	System Wattage
Ballast Dependent	11W	>0.9	13W

BYPASS BALLAST ELECTRICAL CHARACTERISTICS

Input Voltage	Lamp Wattage	Power Factor	System Wattage
120-277V	11W	>0.9	11W

PHOTOMETRIC CHARACTERISTICS

Color Temperature (CCT)	2700K	3000K	35000K	4000K	50000K
Luminous Flux	1000 lm	1000 lm	1000 lm	1050 lm	1050 lm
Color Rendering Index (CRI)	≥ 83	≥ 83	≥ 83	≥ 83	≥ 83
Bare Lamp Efficacy	91 lm/W	91lm/W	91 lm/W	95 lm/W	95 lm/W
Beam Angle	>120°	>120°	>120°	>120°	>120°
LED Quantity	21	21	21	21	21

RATED LIFE

L70 (Hours)	50,000
--------------------	--------

POLAR CANDELA DISTRIBUTION

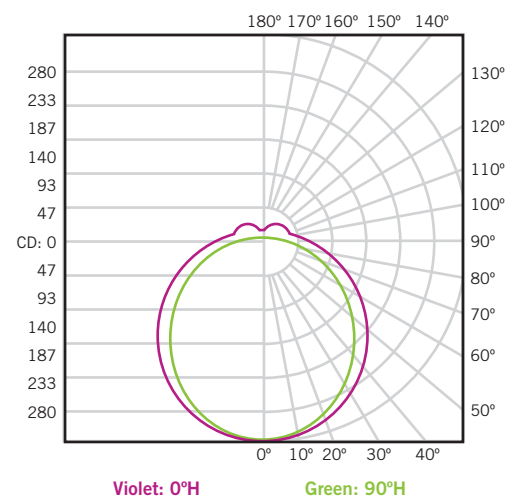



KT-LED112P-V-8xx-X

2-PIN LED LAMP

WIRING

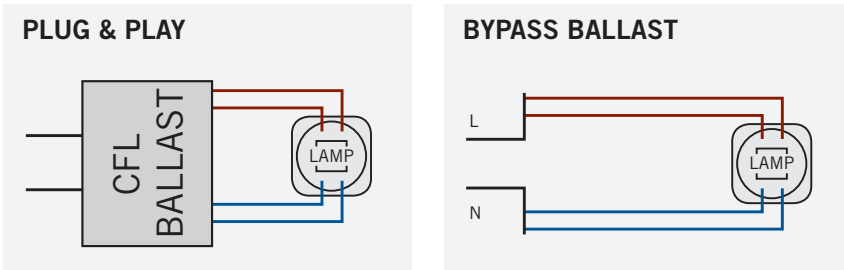

PHYSICAL CHARACTERISTICS

LAMP DIMENSIONS

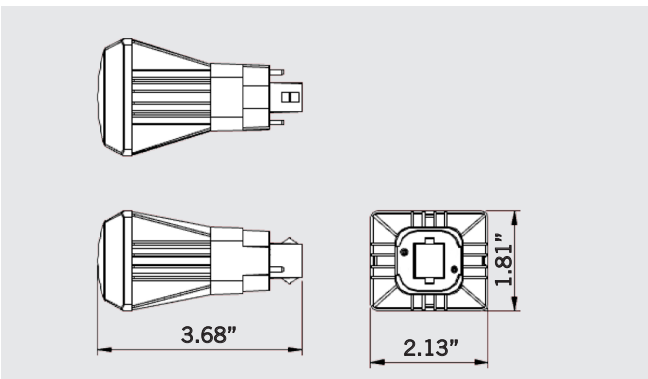

ORDERING INFORMATION

ORDER CODE	PACKAGING STYLE	PACK QTY.	ITEM STATUS
KT-LED112P-V-8xx-X	Distributor Pack	50	Quick Ship

CATALOG NUMBER BREAKDOWN

KT-LED112P-V-8xx-X

