

KETRA[®]

S38 Accessories

- Range of Accessories for S38 PAR lamp to precisely control beam and field of Ketra's S38 lamp.

Hardware Ordering Guide

S38A			
Series	Accessory Type	Cutoff Degree	Housing Color
Series			Code
S38 Accessory			S38A
Accessory Type			Code
Snoot			SNT
Hex Louver (Black only)			LUV
Baffle (Black only)			BFL
Cutoff Degree			Code
55° (Short Snoot)			55
30° (Tall Snoot)			30
45° (Hex Louver) (Requires SNT55)			45
10° (Baffle) (Requires SNT30)			10
Housing Color			Code
White (Snoots Only)			WH
Black			BK

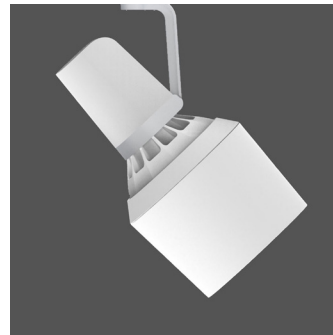

30° Cutoff Tall Snoot



55° Cutoff Short Snoot

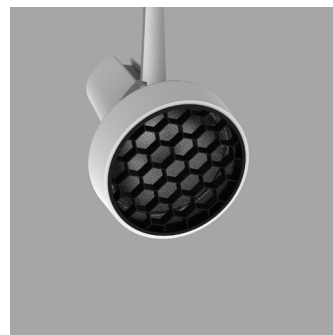

45° Cutoff Hex Louver with
55° Cutoff Short Snoot



10° Cutoff Baffle with
30° Cutoff Tall Snoot

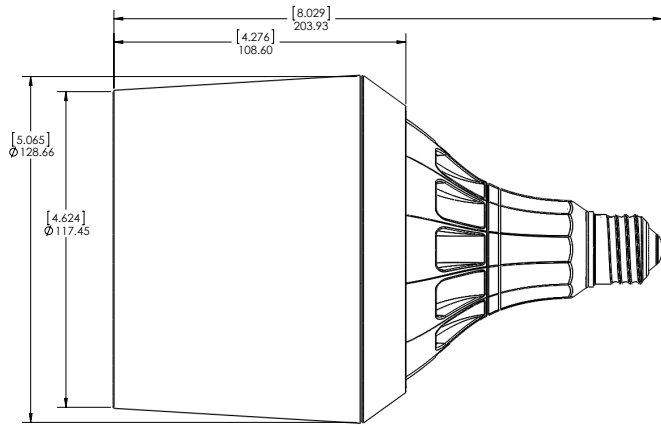

30° Cutoff Tall Snoot

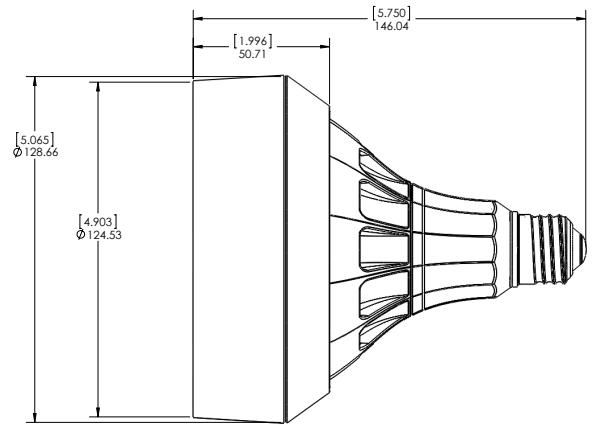

55° Cutoff Short Snoot

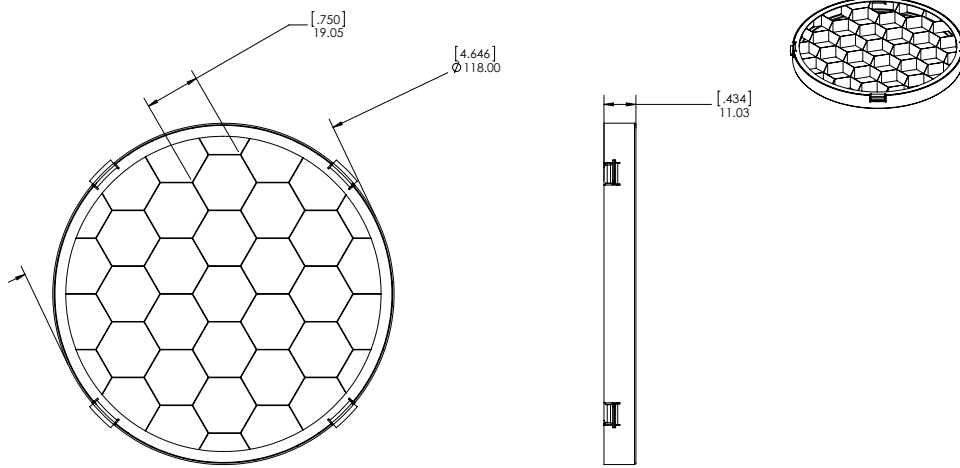

45° Cutoff Hex Louver (Requires 55° cutoff short snoot)

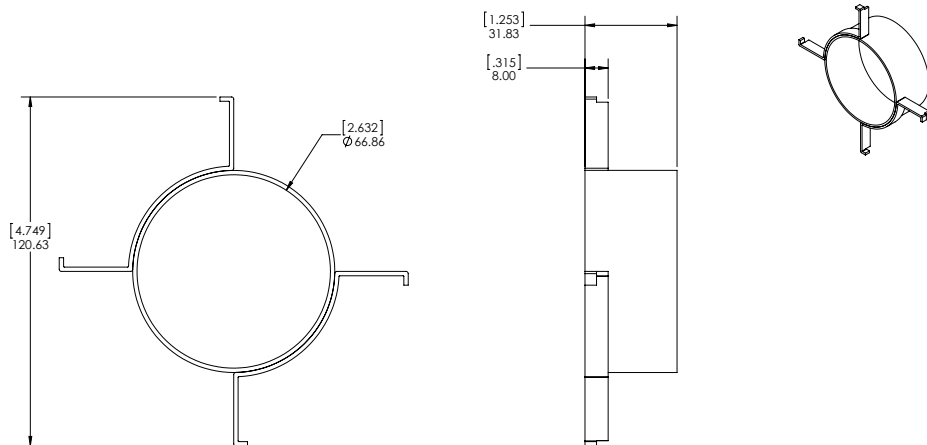

10° Cutoff Baffle (Requires 30° cutoff tall snoot)

770-000021-01-2
 Specifications are subject to change without notice.